

TECHNICAL DATA - TECHNISCHE DATEN - DATI TECNICI DONNÉES TECHNIQUES - DATOS TECNICOS

M038

1) TOOL TYPE - GERAETETYP - DESCRIZIONE MACCHINA - TYPE D'OUTIL - TIPO DE MAQUINA

cod. 11330 FA RR-15/18

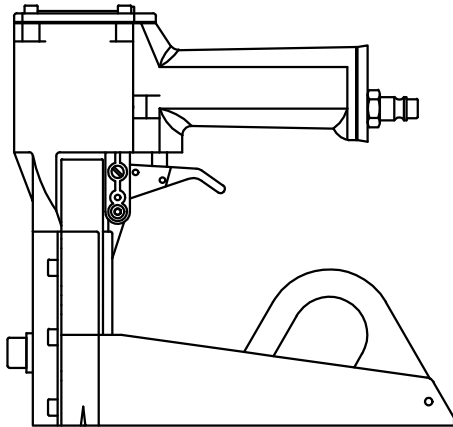

2) TOOL CHARACTERISTICS
SPEZIFICATION DES GERAETES
CARATTERISTICHE TECNICHE
CARACTÉRISTIQUES DE L'OUTIL
CARACTERÍSTICAS DE LA MAQUINA

HEIGHT HOEHE ALTEZZA HAUTEUR ALTURA	WIDTH BREITE LARGHEZZA LARGEUR ANCHURA	LENGTH LAENGE LUNGHEZZA LONGUEUR LONGITUD	WEIGHT GEWICHT PESO POIDS PESO
in. 8.66 mm. 220	in. 4.53 mm. 115	in. 9.20 mm. 233	lbs. 5.13 kg. 2.330
MIN-MAX WORKING PRESSURE MIN-MAX ARBEITSDRUCK MIN-MAX PRESSIONE DI ESERCIZIO MIN-MAX PRESSION DE TRAVAIL MIN-MAX PRESION DE TRABAJO		70 / 100 PSIG 5 / 7 BAR	
AIR CONSUMPTION PER SHOT LUFTVERBRAUCH PRO NAGELUNG CONSUMO ARIA PER COLPO CONSOMMATION DE L'AIRE PAR COUP CONSUMO DE AIRE CADA DISPARO		PERFORMANCES AT 90 psi (0.62 MPa) PRESTAZIONI A 6.2 bar (0.62 MPa) 0.51 l.	
LUBRICANT SCHMIEROEL LUBRIFICANTE LUBRIFIANT LUBRIFICANTE		AEROSPACE LUBRICANTS TRIBOLUBE 12	

* ACTUATION SYSTEM * AUSLÖSEART * ATTUAZIONE * MISE EN ŒUVRE * ACTUACIÓN	5 (SAFETY : NO)
--	------------------------

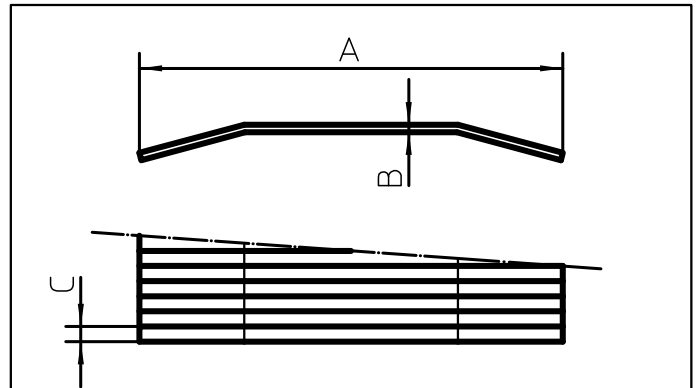

3) FASTENER DATA
ANGABEN ZU DEN BEFESTIGUNGSMITTELN
CARATTERISTICHE TECNICHE FISSAGGI
DONNÉES DES PROJECTILES
DATOS DE CLAVOS

A) OUTSIDE CROWN AUSSEN RUECKEN LARGHEZZA EST. COURONNE EXT. CORONA EXT.	} MAX	in. 2 1/4" - 2 1/2" mm. 57.00 - 64.30
BxC) WIRE DRAHT FILO FIL ALAMBRE		in. 0.035 x 0.075 mm. 0.90 x 1.90
MAGAZINE CAPACITY MAGAZIN CAPAZITAET CAPACITA' CARICATORE CAPACITE' CHARGEUR CAPACIDAD CARGADOR		1000 staples

* LOADING * LADEN * CARICAMENTO * CHARGER * CARGA	<input type="checkbox"/> BOTTOM LOADING <input type="checkbox"/> SIDE LOADING <input type="checkbox"/> TOP LOADING <input type="checkbox"/> COIL <input checked="" type="checkbox"/> OTHER
---	--

* SEE INSTRUCTION MANUAL - SIEHE BETRIEBSANLEITUNG - VEDI MANUALE - VOIR MODE D'EMPLOI - VER EL MANUAL

NOISE CHARACTERISTICS GERÄUSCH - EMISSION DATEN CARATTERISTICHE RUMOROSITA' CARACTÉRISTIQUES ACOUSTIQUE CARACTERÍSTICAS DE RUIDO	EN 12549+A1:2008 $L_{WA,1s}$, :93.00 dB(A) - $K_{WA,1s}$, 2.5 EN ISO 4871:2009 $L_{pA,1s}$, :80.00 dB(A) - $K_{pA,1s}$, 2.5
--	--

VIBRATION VALUE VIBRATIONSWERT VALORE DI VIBRAZIONE VALEUR DE VIBRATION VALOR DE VIBRACIÓN	UNI ISO/TS 8662-11	IS BELOW THE DECLARATION LIMIT SET BY LIEGT UNTER DEM ANZUGEBENEN WERT GEMÄSS RISULTA AL DI SOTTO DEL LIMITE DA DICHI. STABILITO IN RESULTE AU DESSOUS DE LA LIMITE A DECLARER ETABLIE PAR RESULTA SER DEBAJO DEL LIMITE A DECLARAR	UNI EN ISO 12100-1/2
--	-----------------------	---	-------------------------